

Standard Features

- Factory Installed Boiler/System Modulating Pump
- Onboard Outdoor Reset Control System with Sensor Standard
- Priority Domestic Hot Water (DHW) Standard (with Optional 3-way Valve, Not Included)
- Modulating Ceramic Premix Burner
- 5.0:1 Turndown Ratio
- Spark Ignition
- Exceeds SCAQMD 1146.2 Low NO_x Requirements
- Stainless Steel Water Tube Condensing Heat Exchanger
- Direct Vent Sealed Combustion
- Concentric and Twin Pipe Venting Adapters Included
- Approved for Room and Closet Installations

Optional Accessories

- 3-way Valve DHW Kit
- RS100 Single Zone Controller
- Flue Gas Temperature Sensor
- Room Air Filter
- NG to LP Conversion Kit
- NG to LP Conversion Kit

SPECIFICATIONS

General Specifications	
Water Content	1.8 Gal / 7.0 L
Max Supply Boiler Temperature	176 °F / 80 °C
Max Operating Pressure	45 PSI / 310 kPa
Relief Valve Rating	375 MBH / 110 kWh
Relief Valve Pressure Rating	30 PSI / 207 kPa
Unit Weight	141 lbs / 64 kg
Min Inlet Gas Pressure NG	4.0" WC / 10.0 mbar
Max Inlet Gas Pressure NG	10.5" WC / 26.2 mbar
Min Inlet Gas Pressure LP	8.0" WC / 19.9 mbar
Max Inlet Gas Pressure LP	13.5" WC / 33.6 mbar
Electrical Voltage Mains	120 V / 60 Hz
Electrical Voltage Controls	24 V
Power Consumption Max Load	210 W
Power Consumption Standby Load	14 W
Recommended Circuit Breaker Rating	15 A
Sound Level	54 dB

Performance Specifications	
Fuel Types	NG and LP
Input (Heating)	175 MBH / 51.0 kWh
Heating Capacity	162 MBH / 47.5 kWh
Input (DHW)	N/A
Minimum Input	NG: 35 MBH / 10.3 kWh LP: 74 MBH / 21.7 kWh
Turndown Ratio	5.0:1 / 2.4:1 TDR
System Pump Model	UPER 20-78
Max Head Pressure at Flow Rate	16.4 ft at 5.0 GPM 5.0 m at 18.9 LPM
AFUE	95.0%
DHW Flow Rate 75°F ΔT	N/A
DHW Minimum Activation	N/A
Flow Restrictor Color	N/A
Max Equivalent Exhaust Vent Length	80 ft / 24.4 m
Max Equivalent Combustion Air Vent Length	80 ft / 24.4 m
Approved Venting Materials	Polypropylene, Stainless Steel, PVC, CPVC



Rinnai is continually updating and improving products; therefore, specifications are subject to change without prior notice. Local, state, provincial and federal codes must be adhered to prior to installation.

DIMENSIONS

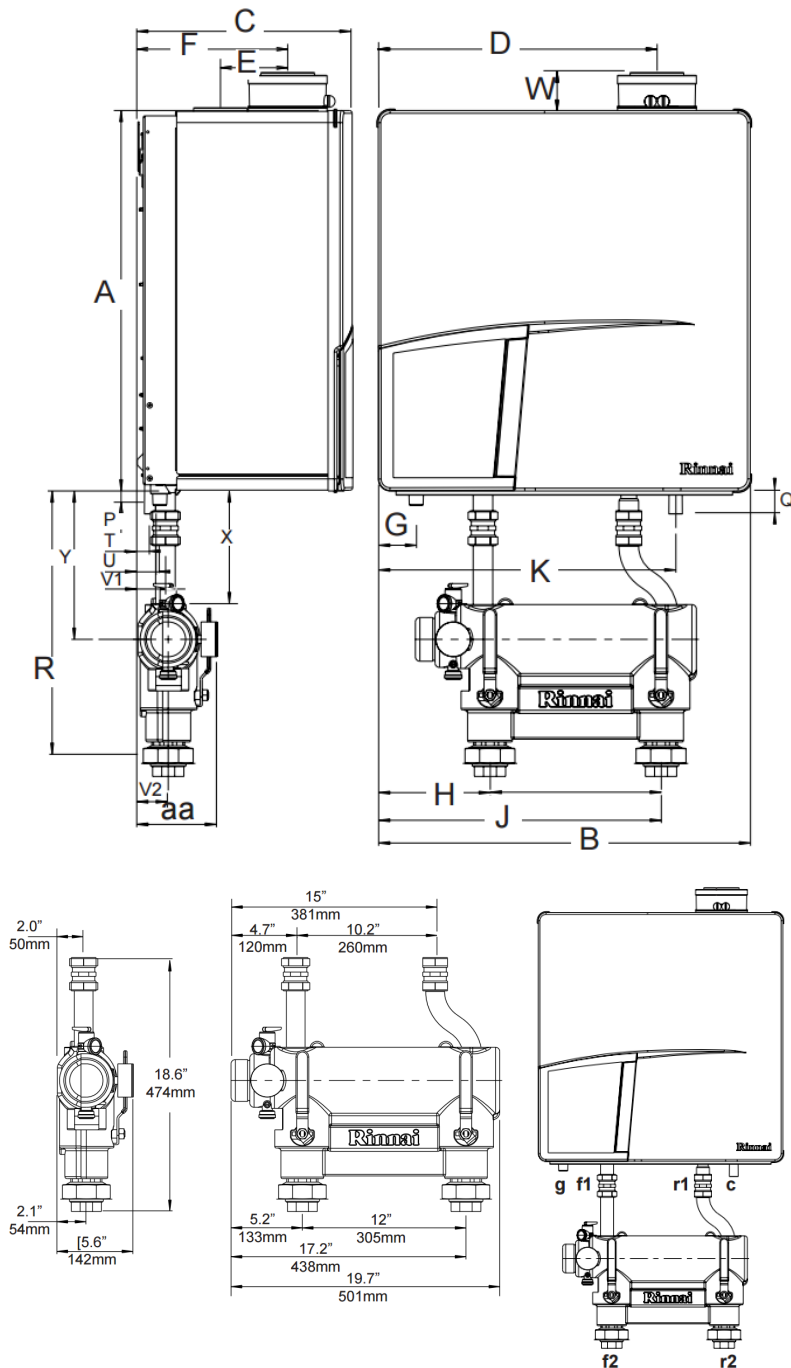

A	Height	26.8" / 680 mm
B	Width	26" / 660 mm
C	Depth	15.2" / 385 mm
D	Left Side / Vent	19.5" / 495 mm
E	Center to Center / Vent and Air Supply	4.7" / 121 mm
F	Back / Vent	10.6" / 270 mm
G	Left Side / Gas Pipe	2.6" / 65 mm
H	Left Side / Supply Pipe	7.8" / 199 mm
J	Left Side / Return Pipe	19.8" / 504 mm
K	Left Side / Condensate Pipe	20.9" / 530 mm
P	Pipe Length of G	0.7" / 18 mm
Q	Pipe Length of C	2" / 50 mm
R	Pipe Length of F and R	18.5" / 470 mm
T	Back / Center of Pipe C	1" / 25 mm
U	Back / Center of Pipe G	1.6" / 40 mm
V1	Back / Center of Pipes f1 and r1	2" / 50 mm
V2	Back / Center of Pipes f2 and r2	2.1" / 54 mm
W	Pipe Length Vent Co-axial Pipe Length Vent Parallel	2.6" / 65 mm 5.8" / 147 mm
X	Bottom Side Boiler to Center Pressure Relief Valve	7.7" / 195 mm
Y	Bottom Side Boiler to Center Low Loss Header	10.2" / 260 mm
Z	Center to Center f2 to r2	9" / 229 mm
aa	Depth of Low Loss Header	5.6" / 142 mm

Clearances

	Minimum required clearance to combustibles and non-combustibles	Recommended service clearances
Top	2" / 50 mm	10" / 250 mm
Back	0	0
Front	6" / 150 mm	24" / 600 mm
Left Side	2" / 50 mm	2" / 50 mm
Right Side	2" / 50 mm	2" / 50 mm
Floor / Ground	12" / 300 mm	30" / 762 mm
Floor / Ground to Bottom of Low Loss Header	0	12" / 300 mm
Vent	0	0