

Technical Bulletin 134 - RUR98i/e Piping Diagrams and Pump Settings for 2-Unit Installations

The purpose of this technical bulletin is to provide clarification on 2-unit installations, as well as pump settings involving the SE+ Series featuring ThermaCirc360™ product line (RUR98i/e models).

2-Unit Dedicated Return Line

In applications utilizing a dedicated return line:

- The tankless water heater WITH a recirculation pump will be the PRIMARY unit feeding off the cold water supply line.
- The tankless water heater WITHOUT a recirculation pump will be the SECONDARY unit feeding off the cold water supply line.

The water heaters are separated by a check valve and PVA valve. During a “normal” demand situation, the primary unit feeding off the cold water supply line produces hot water to meet the demand. In higher demand draws where a single unit is not sufficient, the PVA valve opens and the secondary water heater turns on to meet the demand for hot water.

When recirculation is active, the tankless water heater with a recirculation pump will turn on and circulate water through the loop and back to the dedicated recirculation unit, maintaining the temperature in the system.

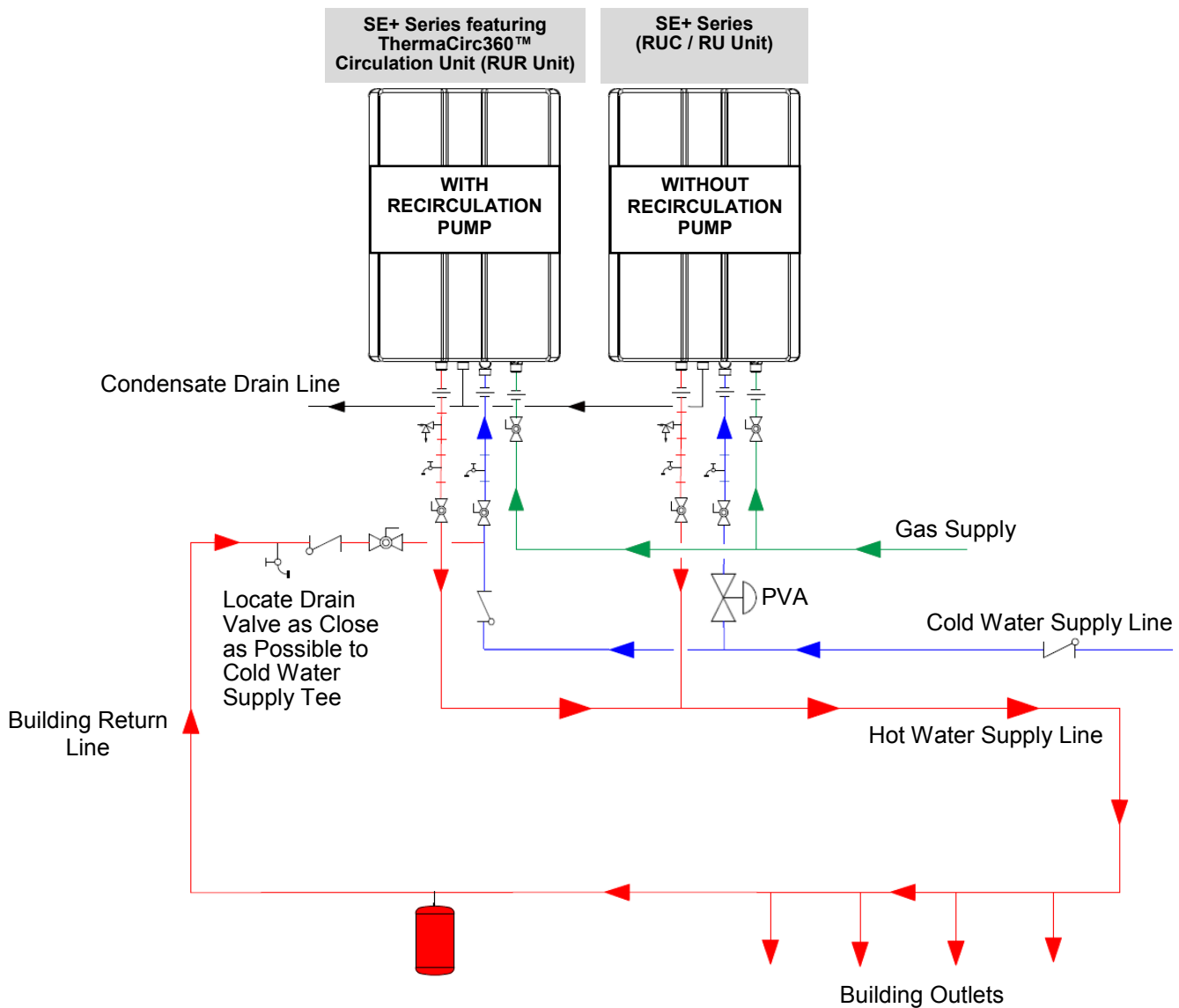

2-Unit Crossover Valve

In applications utilizing a crossover valve recirculation system:

- The tankless water heater WITH a recirculation pump will be the PRIMARY unit feeding off the cold water supply line.
- The tankless water heater WITHOUT a recirculation pump will be the SECONDARY unit feeding off the cold water supply line.

The water heaters are separated by a PVA valve. During a “normal” demand situation, the first unit feeding off the cold water supply line produces hot water to meet the demand. In higher demand draws where a single unit is not sufficient, the PVA valve opens and the second water heater turns on to meet the demand for hot water.

When recirculation is active, the tankless water heater with a recirculation pump will turn on and circulate water to the fixture with the crossover valve and back to the tankless water heater using the cold water feed line as the recirculation line, maintaining the temperature in the system.

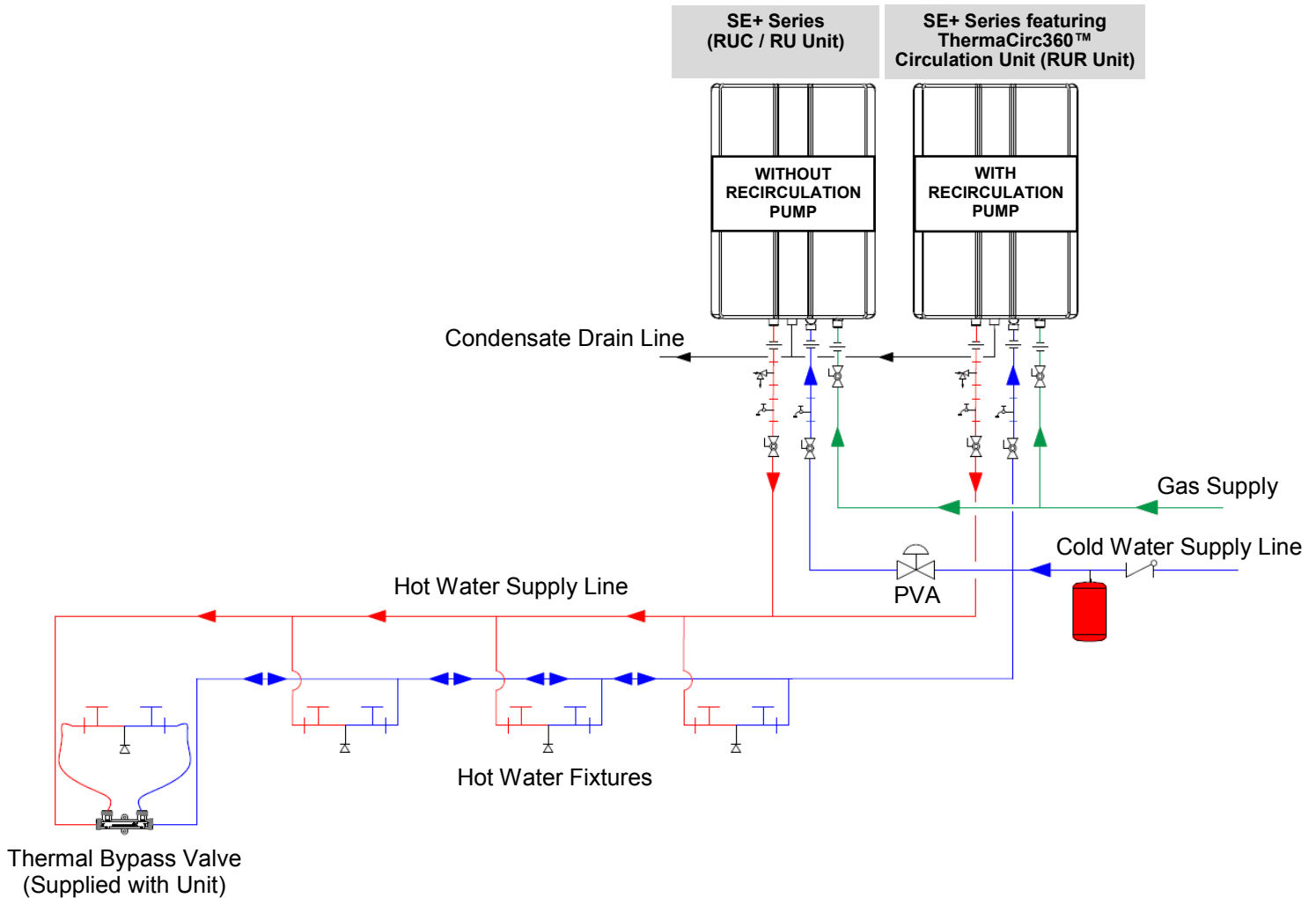

SE+ Series Featuring ThermaCirc360™ Models Only (RUR98e and RUR98i) Pump Settings

RECIRCULATION PUMP

IMPORTANT: RECIRCULATION PUMP SETTINGS

SE+ Series Featuring ThermaCirc360™ Models Only (RUR98e and RUR98i)

Refer to the Recirculation Modes section in Installation and Operation Manual for complete instructions.

Dip Switch Settings Calculator

Scan the QR Code with your handheld device to access the Dip Switch Settings Calculator for models featuring ThermaCirc360™. The calculator will show you step-by-step how to set the dip switches for your specific application.



- Ensure recirculation pump settings are configured.

Maximum Pipe Length*		
Pipe Diameter	3/4"	1/2"
Total	400 Ft	100 Ft

Below are important steps to follow when configuring Dedicated Recirculation Line Mode and Crossover Mode settings:

	Switch #4	Switch #7	Switch #8
Economy Mode**	OFF	ON	OFF
Comfort Mode**	OFF	ON	ON
Pump Off	OFF	OFF	OFF

* Maximum pipe length includes both hot water supply and dedicated return lines. Take equivalent elbow lengths into consideration when calculating pipe length.

• DEDICATED RECIRCULATION

LINE MODE:

If using Dedicated Recirculation Line mode (factory default), determine maximum pipe length:

Configure dip switches #4, #7 and #8 in the second (or lower) group of switches (DIPSW 2) as shown in the table below.

Pipe Diameter	Short Loop	Long Loop
3/4"	Up to 200 Ft	From 201 to 400 Ft
1/2"	Up to 50 Ft	From 51 to 100 Ft

• CROSSOVER MODE:

Loop	Mode**	Switch #4	Switch #7	Switch #8
Short	Economy	ON	ON	OFF
Short	Comfort	ON	ON	ON
Long	Economy	ON	OFF	OFF
Long	Comfort	ON	OFF	ON

If

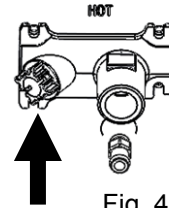

Fig. 4

** Modes:

Economy mode:
Less energy consumed due to fewer pump cycles.

Comfort mode:
Higher energy consumed due to more pump cycles.